

Fabco Power



Setting the Standard in Mobile Power

Instruction Manual for Model

HYDRO

12K-CD-16

Hydraulic Generator

Manufacturing of: Vehicle Mounted Generators • Hydraulic Generators

P.O. Box 582 • Chester, NY 10918 • 845-469-9151 • Fax: 845-469-7871 • Web Site: www.fabcopower.com

GENERAL INFORMATION

MODEL: HYDRO 12KCD-16

GENERATOR..... BRUSHLESS

GENERATOR..... 3600 (60 Hz)

GENERATOR VOLTAGE..... 120 or 120/240

MOTOR STARTING..... 300% SURGE

VOLTAGE REGULATOR..... INHERENT

OUTPUT..... 12 KW CONTINUOUS
13KW CONTINUOUS PEAK
AT 100° F OIL TEMPERATURE

HYDRAULIC MOTOR..... GEAR TYPE

FLOW CONTROL (OPTIONAL)..... CARTRIDGE TYPE

MAXIMUM SPEED..... 4200 RPM
(3600 RPM IDEAL)

MOTOR SHAFT..... $\frac{3}{4}$ "

CONTINUOUS
PRESSURE RATING..... 2,800 PSI

PORT SIZE

INLET..... 1 1/16 - 12 S.A.E.

RETURN..... 1 5/16 - 16 S.A.E.

CASE DRAIN..... 7/16 4 S.A. E

RECOMMENDATIONS **MODEL: HYDRO 12KCD-16**

HIGH PRESSURE LINE 3/4 inch

LOW PRESSURE LINE..... 1 inch

CASE DRAIN..... 1/2 inch

FLOW CONTROL..... 16 GPM IDEAL

DO NOT EXCEED 175°F. HYDRAULIC OIL TEMPERATURE, FOR BEST RESULTS KEEP OIL TEMPERATURE BELOW 120°F. AN OIL COOLER IS RECOMMENDED.

MAXIMUM BACK PRESSURE 150 PSI

OPEN CENTER 2500 PSI SYSTEMS.

RECOMMEND FILTER 10m

RECOMMEND HYDRAULIC OIL DEXTRON III A.T.F.

RECOMMEND RESERVOIR SIZE..... MINIMUM 50 GAL.

INSTALLATION TIPS

If our hydraulic generator is to be used on a truck or system that will be changing speeds, such as, in a fire truck (pumping water) we suggest you use a load sensing piston type pump rather than a fixed displacement gear type. The system will run much cooler and more efficient.

Initial Installation and Start-Up

Be sure you set the hydraulic flow (GPM) to the generator at Approximately 62.5 HZ or 3750 RPM with NO electrical load on the generator.

By using this setting you will have approximately 60HZ (cycles) or 3600 RPM when you are running at full rated load.

One way this can be accomplished is by using a Photo Tachometer on our generator coupling or generator cooling fan.

A Photo Tachometer is an inexpensive tool that can be purchased at McMasters, Grainger, Sears or any other electrical supplier.

TECHNICAL INFORMATION

These self-excited and self-regulating generators, although overall dimensions have been reduced to a minimum, are designed for high-level electrical performance and the maximum in operating reliability.

PRELIMINARY CHECKS:

Before touching the machines, perform a thorough and in depth visual inspection, checking that components are correctly connected up and that no cables or terminals are broken or loose.

STARTING UP:

Make sure, when starting up, that cooling air intake and discharge openings are free and unblocked. We also recommend (when the machine operates in a dusty environment) do periodic checks to make sure it is properly ventilated

THE IMPORTANCE OF SPEED:

Frequency and voltage depend directly on rotation speed. This must be kept as constantly as possible on its nominal value no matter what the load. Drive motor speed control systems generally have a small drop in speed between no load and loaded conditions. We therefore recommend setting no load speed 3-4% above nominal speed.

CHECKING VOLTAGE:

All the machines are regulated during factory testing. If voltage readings differ from the value indicated on the name plate, this maybe caused by a mistaken reading or by a different rotation speed and we recommend regulating motor speed in order to have nominal RPM under loaded conditions.

CHECKING THE DIODES:

For the ohmmeter test it is best to disconnect the diode from its circuit. Measure continuity in one direction only. The test can also be made without disconnecting the diode from the circuit, using a 12V battery and a 45 watt light bulb (automobile light) as shown in the illustration. The light should turn totally on only in one direction, as shown below.

**WINDING RESISTANCE AT 20° C
ROOM TEMPERATURE**

<u>Size</u>	<u>Stator Ω</u>	<u>Rotor Ω</u>	<u>Exciter Ω</u>
3.5	0.7	9.22	4.0
4.0	0.7	9.28	4.0
5.0	0.54	2.97	2.24
6.0	0.54	2.97	2.24
8.0	0.49	2.85	4.41
10.0	0.109	4.67	1.30
12.0	0.130	5.23	1.40

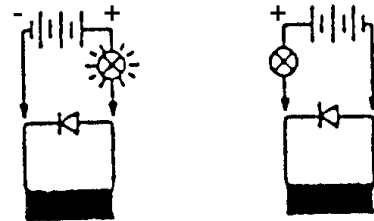

ELECTRICAL CONNECTIONS

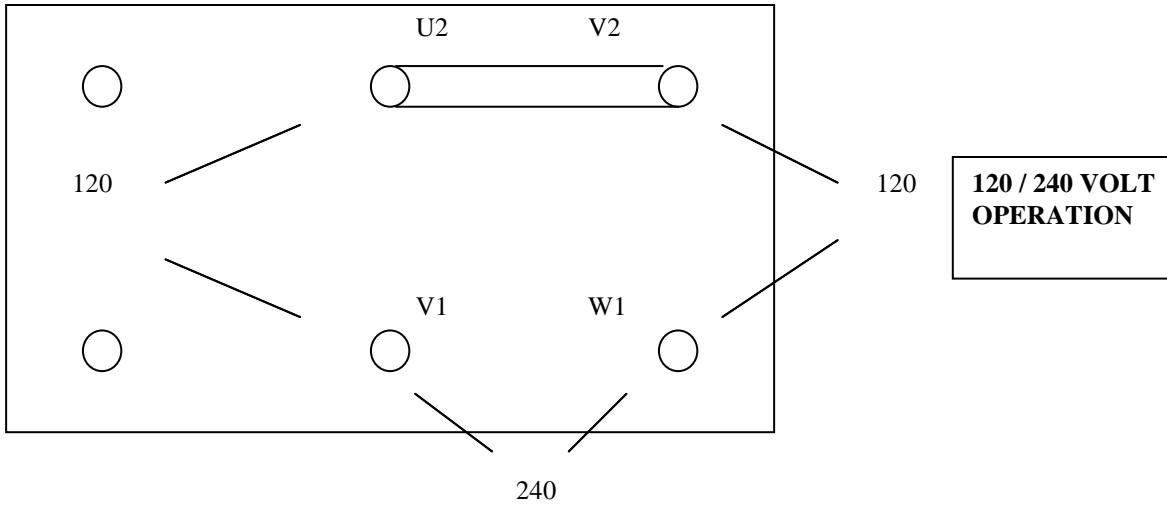

TERMINAL BLOCK

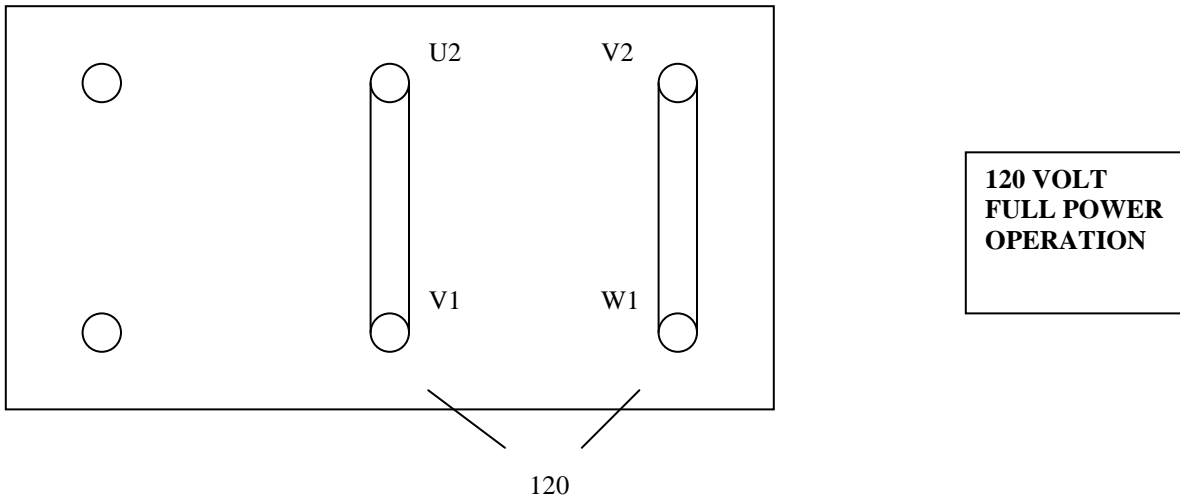

TERMINAL BLOCK

PARTS BREAKDOWN

HYDRO 12KCD-16

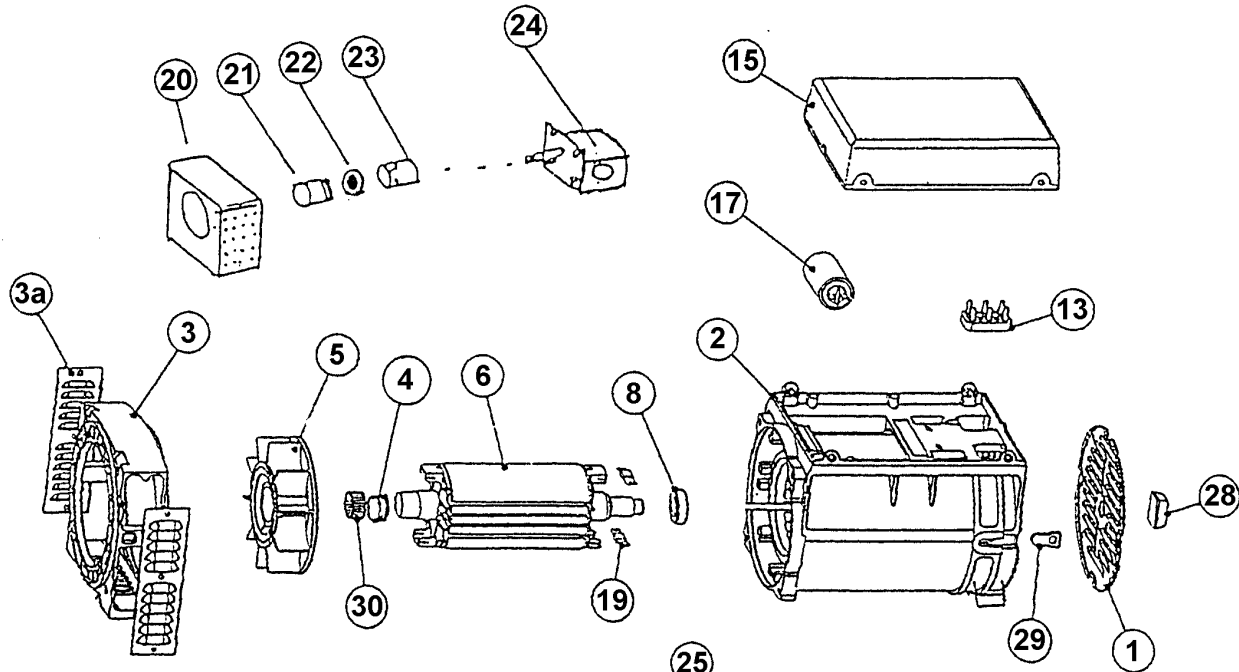

No.	PART #	DESCRIPTION
1	572416	Louvered Panel
2	572419	Frame For Stator
3	572420	Drive End Bell
3a	572428	Screen
4	572423	Front Bearing
5	572422	Fan
6	572421	Rotor
8	572424	Rear Bearing
13	572418	User Terminal Board
15	572417	Cover
17	572475	Capacitor 35
19	572425	Diodes
20	572616	Pump Mount
21	572281	Coupling 28mm
22	572282	Spider
23	572246	Coupling 3/4
24	572362	Motor 16cc case/drain
25	572303	Rails
26	572154	Mounts
28	572431	Stud Cover
29	572430	Rubber Cup
30	572428	Fan Ring
	572233	Flow Control Assy (opt.)
	572240	Flow Control Cartridge only (opt.)
	572254	Seal For Hydraulic Motor
	572352	Generator Complete

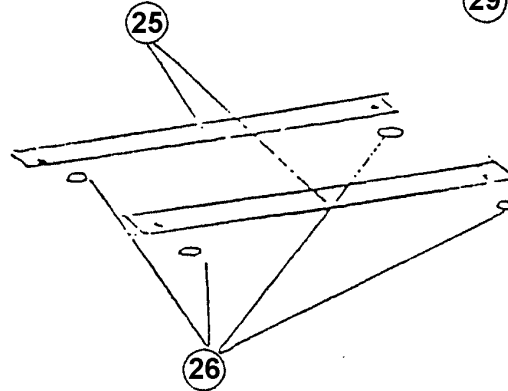

PART #	OPTIONAL CONTROL PANEL
572227	Complete Control Panel
572228	Control Box (Shell)
572052	Volt Meter
572054	Receptacle 120 Volt
572100	Waterproof Recpt. Cover
572226	GFI Control Panel

TROUBLE SHOOTING

PROBLEMS	CAUSES	REMEDIES
ALTERNATOR EXCITATION FAILURE	<ol style="list-style-type: none"> 1. Low Speed 2. Faulty capacitor 3. Faulty winding 	<ol style="list-style-type: none"> 1. Check RPM and set at nominal value. 2. Check and replace. 3. Check that winding resistance is as shown in the tables.
HIGH NO-LOAD VOLTAGE	<ol style="list-style-type: none"> 1. Speed too high. 2. Capacitor with high capacity. 	<ol style="list-style-type: none"> 1. Check and adjust RPM's 2. Check and replace
LOW NO-LOAD VOLTAGE	<ol style="list-style-type: none"> 1. Speed too low. 2. Faulty rotary diodes. 3. Breakdown in windings. 4. Capacitor with high capacity. 	<ol style="list-style-type: none"> 1. Check and adjust RPM's 2. Check and replace. 3. Check winding resistance, as per tables. 4. Check and replace.
PROPER NO-LOAD BUT LOW LOADED VOLTAGE	<ol style="list-style-type: none"> 1. Low loaded speed. 2. Load too large. 3. Rotary diodes short-circuited 	<ol style="list-style-type: none"> 1. Check and regulate RPM. 2. Check and change. 3. Check and replace.
UNSTABLE VOLTAGE	<ol style="list-style-type: none"> 1. Loose contacts. 2. Uneven rotation. 	<ol style="list-style-type: none"> 1. Check connections. 2. Check for uniform rotation speed.
NOISY GENERATOR	<ol style="list-style-type: none"> 1. Broken bearings. 2. Poor couplings. 	<ol style="list-style-type: none"> 1. Replace. 2. Check and repair.

FIXED DISPLACEMENT TYPE GEAR PUMP

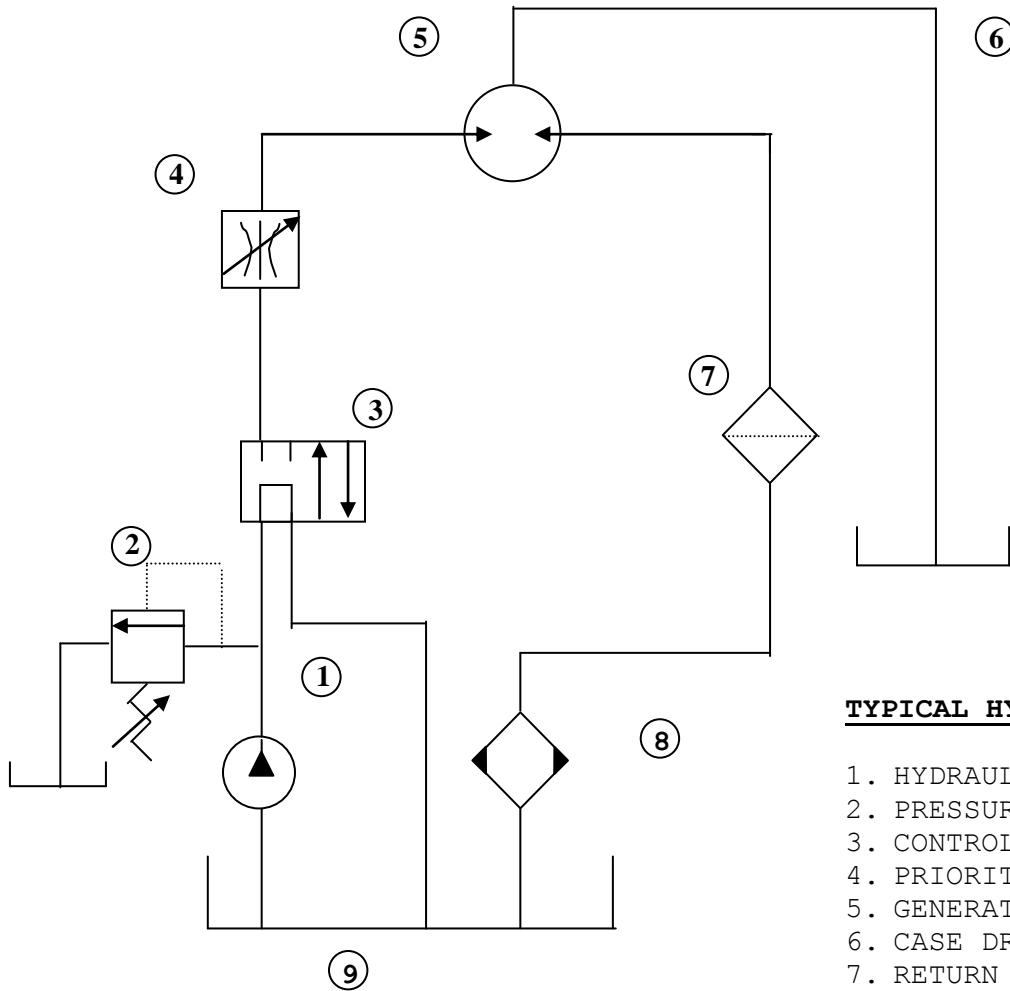

TYPICAL HYDRAULIC SCHEMATIC

1. HYDRAULIC PUMP
2. PRESSURE RELIEF VALVE
3. CONTROL VALVE
4. PRIORITY FLOW CONTROL*
5. GENERATOR HYRAULIC MOTOR
6. CASE DRAIN LINE**
7. RETURN LINE FILTER
8. OIL COOLER
9. HYDRAULIC FLUID RESERVOIR

* Some units may be equipped with integral priority flow control, refer to specific model number.

** External case drain line may be required on some units refer to specific model number.
When external case drain is required it should be unobstructed direct return to reservoir with a minimum I.D. no less than that of case drain port on generator motor.

FOR SPECIFIC INSTALLATION RECOMMENDATIONS CONSULT FACTORY

FABCO BY-PASS FLOW CONTROL

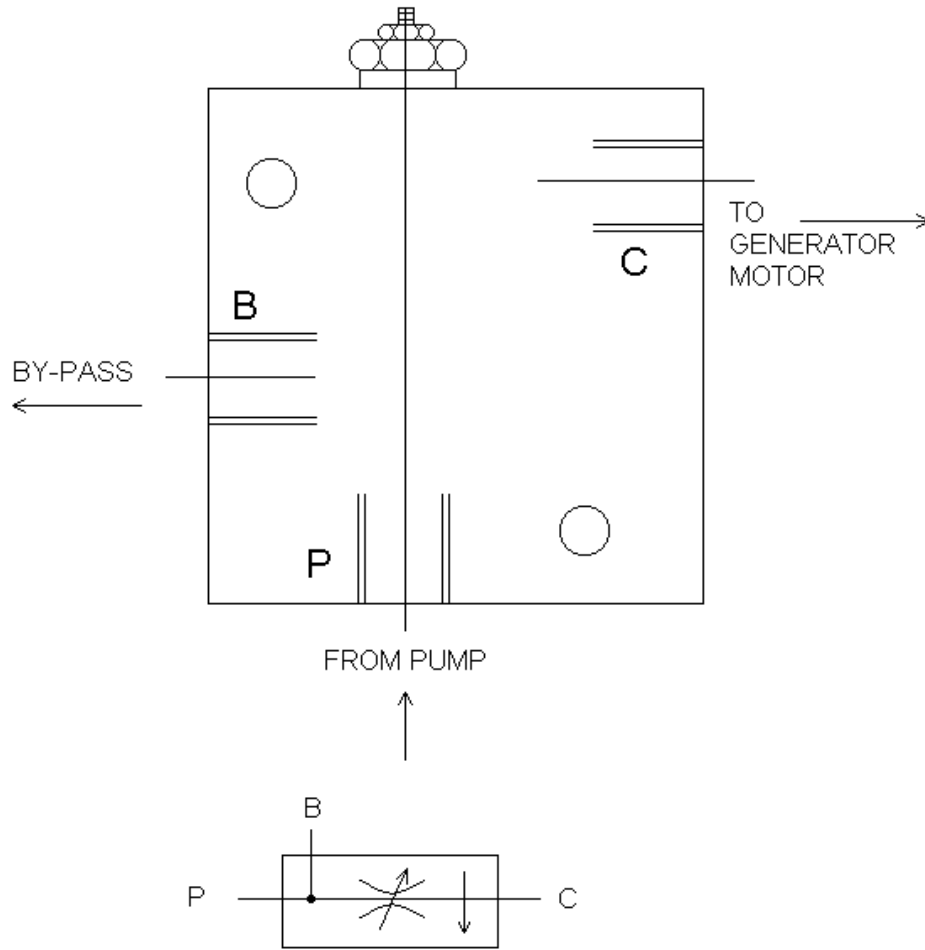

FABCO PN 572233

**NOTE: THIS ASSEMBLY ONLY NEEDED
WITH FIXED DISPLACEMENT TYPE
GEAR PUMP.**

REVISIONS

LTR	DESCRIPTION	DATE	INITIALS

TYPICAL HYDRAULIC SCHEMATIC

PISTON TYPE, LOAD SENSING

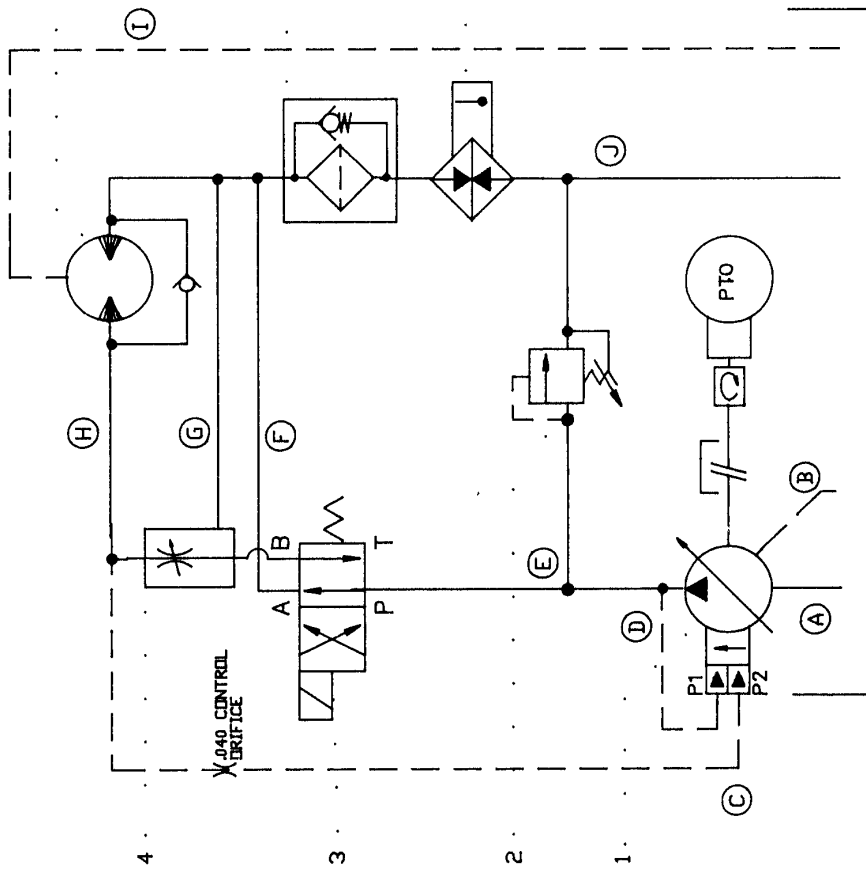

ITEM	QTY	ITEM	DESCRIPTION
1	1	HYDRAULIC PUMP	PISTON TYPE V/LOAD SENSE
2	1	RELIEF VALVE	SET AT 3000 PSI
3	1	DIRECTIONAL VALVE	(SEE NOTE 'A')
4	1	FLOW CONTROL	(SEE NOTE 'A')
5	1	HYDRAULIC MOTOR	WITH EXTERNAL CASE DRAIN
6	1	FILTER	RETURN LINE V/BYPASS
7	1	HEAT EXCHANGER	
8	1	HYDRAULIC RESERVOIR	

CUSTOMER CONNECTIONS & LINE SIZES	
DES	SIZE DESCRIPTION
A	1-1/4 SUCTION LINE
B	3/8 PUMP CASE DRAIN
C	1/4 EXTERNAL SENSE LINE
D	N/A INTERNAL SENSE LINE
E	1' MAIN SUPPLY LINE
F	3/4 PRESSURE LINE
G	3/4 PRESSURE LINE
H	3/4 PRESSURE LINE
I	3/8 MOTOR CASE DRAIN
J	1' RETURN LINE

- * * * * *
- * * * * *
- * * * * *
- * * * * *
- * * * * *
- * * * * *

* REQUIRED ON SOME MODELS. REFER TO SPECIFIC MODEL NUMBER.

NOTE 'A'

SUPPLIED ON SOME MODELS. REFER TO SPECIFIC MODEL NUMBER.

FOR SPECIFIC INSTALLATION
RECOMMENDATIONS CONSULT
FACTORY

F A B C O P O W E R

CHESTER, NY

MAX FLOW	DATE
MAX PRESSURE	TITLE